

# Product Specifications

## SM57 Cardioid Dynamic Microphone

### Overview

An industry-standard, highly versatile cardioid dynamic microphone that can be found onstage and in studios around the world. The ideal choice for sound reinforcement and recording applications, the legendary SM57 is tuned for clean reproduction of amplified and acoustic instruments, targeting the main sound source while minimizing background noise.

### Features

- Frequency response tailored for drums, guitars, and vocals
- Uniform cardioid pickup pattern isolates the main sound source while reducing background noise
- Pneumatic shock-mount system cuts down handling noise
- Extremely durable under the heaviest use
- Supplied break-resistant swivel adapter that rotates 180°
- Legendary Shure quality, ruggedness, and reliability

### Available Models

<b>SM57-LC</b>	Includes Stand Adapter and Zippered Pouch
<b>SM57-LCE</b>	Includes 5/8-inch to 3/8-inch thread adapter for mounting on European stands, Swivel Adapter and a Zippered Pouch

### Specifications

Type	Dynamic
Frequency Response	40 to 15,000 Hz
Polar Pattern	Cardioid
Sensitivity (at 1,000 Hz Open Circuit Voltage)	Open Circuit Voltage: -56.0 dBV/Pa* (1.6 mV) *(1 Pa = 94 dB SPL)
Impedance	Rated impedance is 150Ω (310Ω actual) for connection to microphone inputs rated low impedance.
Polarity	Positive pressure on diaphragm produces positive voltage on pin 2 with respect to pin 3.
Case	Dark gray, enamel-painted, die-cast steel with a polycarbonate grille and a stainless steel screen.
Connector	Three-pin professional audio connector (male XLR type)
Net Weight	284 grams (10 oz)
Dimensions	157 mm (6-3/16 in.) L x 32 mm (1-1/4 in.) W at the widest point



SM57

### Optional Accessories and Replacement Parts

<b>A2WS</b>	Locking Windscreen	<b>A55M</b>	Isolation Mount	<b>C25F</b>	7.6 m Cable (25 ft)
<b>A25D</b>	Microphone Clip	<b>A26M</b>	Dual Mount	<b>RK143G</b>	Screen and Grille Assembly
<b>R59</b>	Cartridge	<b>S37A, S39A</b>	Desk Stand		

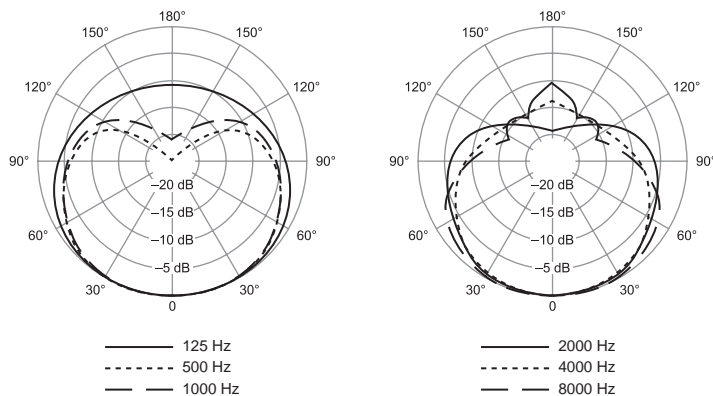

Polar Pattern

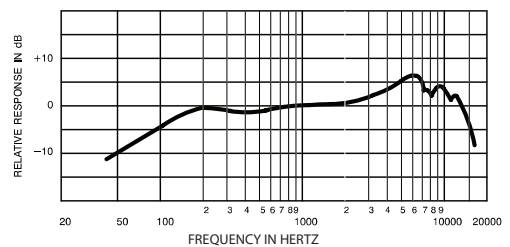

Frequency Response

