

SHURE®

LEGENDARY
PERFORMANCE™

WIRED MICROPHONE

PGA DRUM MICROPHONE KIT USER GUIDE



© 2015 Shure Incorporated
27A24483 (Rev. 2)
Printed in U.S.A.



PG Alta™ Drum Microphone Kit

PG Alta Microphones

Congratulations on the purchase of a new Shure PG Alta series microphone. The PG Alta series delivers professional quality audio at an affordable price, with solutions for capturing nearly any source, including voice, acoustic instruments, drums, and amplified electric instruments. Suitable for live and studio applications, PG Alta microphones are built to last, and meet the same rigorous quality testing standards that make all Shure products trustworthy and reliable.

Drum Kit Bundle Variations

4-Piece Kit

(PGADRUMKIT4)

- PGA52 kick drum microphone
- PGA57 snare drum microphone
- (2) PGA56 drum microphones
- (2) AP56DM mount

5-Piece Kit

(PGADRUMKIT5)

- PGA52 kick drum microphone
- PGA57 snare drum microphone
- (3) PGA56 drum microphones
- (3) AP56DM mount

6-Piece Kit

(PGADRUMKIT6)

- PGA52 kick drum microphone
- PGA57 snare drum microphone
- (2) PGA56 drum microphones
- (2) PGA81 overhead condenser microphones
- (2) AP56DM mount

7-Piece Kit

(PGADRUMKIT7)

- PGA52 kick drum microphone
- PGA57 snare drum microphone
- (3) PGA56 drum microphones
- (2) PGA81 overhead condenser microphones
- (3) AP56DM mount

Note: Availability of specific bundles varies by region. Contact your local Shure distributor for details.

Setting up Drum Microphones

Before you begin, review these fundamental concepts to get the best possible results:

Tuning: Before recording a drum kit, make sure the drums are tuned. A well-tuned kit significantly improves the sound quality for recording and live sound reinforcement. It also makes mixing and signal processing easier, faster, and more effective.

Placement: Use the proximity effect to your advantage when increased bass is desired. Small changes in microphone placement (distance and angle) strongly impact the sound characteristics. If time permits, experiment with various microphone positions to achieve the preferred sound.

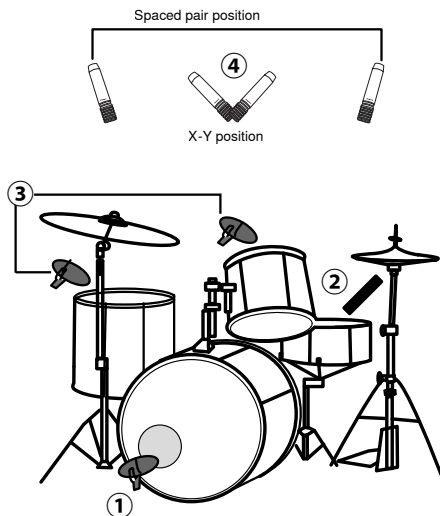

① Kick (PGA52)

- Place the microphone in front of the resonant kick drum head.
- If there is a hole in the head, place the microphone inside for better isolation. Removing the resonant head and placing the microphone closer the beater head provides increased attack.
- To reduce the sustain and overtones for a focused attack, try using a pillow inside the kick drum.

② Snare (PGA57)

- Place the microphone 1-4 inches above the drum, near the rim.
- Point towards the center of the head to capture more stick attack, or closer the edge to capture more overtones.
- Aim the microphone with the rear side pointed towards the hi-hat to reduce the amount of cymbal in the snare drum signal.

③ Toms (PGA56)

- Place the microphone 1-4 inches above the drum, near the rim.
- Use the included AP56DM drum mounts to attach the PGA56 onto the drum. The microphone can also be mounted on a standard 5/8" microphone stand.
- Point towards the center of the head for a deeper sound, or closer the edge to capture more overtones.

④ Overheads (PGA81)

Overhead microphones capture cymbals and an overall stereo image of the drums. Refer to the stereo microphone techniques section for details.

Overhead microphone tips:

- Pan one microphone to the left and the other to the right on a mixer or in recording software to create a stereo image
- The farther the left and right signals are panned, the wider it will sound
- Overheads can be panned from the audience or drummer's perspective, depending on preference. Pan the toms to match the overhead panning for an accurate stereo sound.
- Other stereo drum recording techniques to learn about include the Glyn Johns method, Recorderman, and Mid-Side.
- Additional information on recording drums and microphone techniques is available at shure.com

Proximity Effect

Directional microphones progressively boost bass frequencies as the microphone is placed in closer proximity to the source. This phenomenon, known as proximity effect, can be used to create a warmer, more powerful sound.

Avoiding Pickup of Unwanted Sound Sources

Place the microphone so that unwanted sound sources, such as monitors and loudspeakers, are directly behind it. To minimize feedback and ensure optimum rejection of unwanted sound, always test microphone placement before a performance.

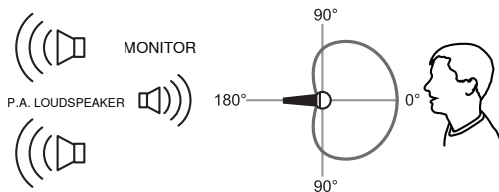

Recommended Loudspeaker Locations for Cardioid Microphones

Phantom Power

All condenser microphones require phantom power to operate. This microphone performs best with a 48 V DC supply (IEC-61938), but it can operate with lower voltages.

Phantom power is provided by the mixer or audio interface that the microphone is connected to, and requires the use of a **balanced** microphone cable: XLR-to-XLR or XLR-to-TRS. In most cases, there is a switch or button to activate the phantom power. See the user guide for the mixer or interface for additional information.

NOTE: Applies to PGA81 condenser microphones only. Supplying phantom power to the other included microphones will not cause damage.

Microphone Techniques for Stereo Recording

Stereo recording using two microphones adds realism by capturing sound similar to the way that humans hear. Panning (directing the signals left and right) adds width and directionality when listening on stereo systems or headphones.

Tip: Panning the signals farther apart increases stereo separation and width. Be careful of panning too far, as it may result in a hollow sound in the middle of the stereo field.

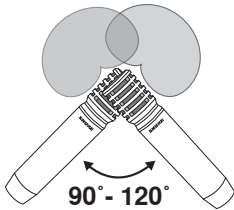

① X-Y Coincident Pair

The X-Y technique provides excellent phase coherency because sound arrives simultaneously at both microphones.

Placement: Set up the microphones with the capsules close together, but not touching. Experiment with angles between 90 and 120 degrees to capture the full width of the source.

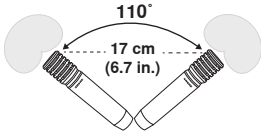

② ORTF

Developed as a French broadcasting standard, ORTF technique replicates the spacing and angle of human ears. It provides a natural, wide sound.

Placement: Angle the microphones at 110°, with the capsules 17 cm apart.

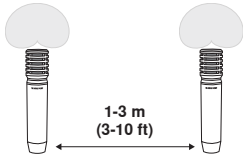

③ A/B Spaced Pair

Spaced pair recording can deliver a dramatic stereo effect because sound arrives at each microphone at a slightly different time, providing the listener with timing cues that localize sounds.

Note:

For drum overheads, the snare drum should be equidistant from each microphone to achieve a tight, focused sound. Use a measuring tape or piece of string to verify this distance.

Using the Quick-Release Lever

PGA56 and PGA52 microphones feature a quick-release lever to easily adjust position.

1. Pull the lever open
2. Move the microphone into the desired position
3. Press the lever back towards the microphone to tighten

Pictured is the PGA56.

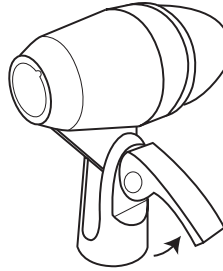

1

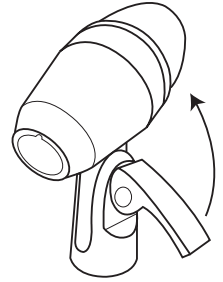

2

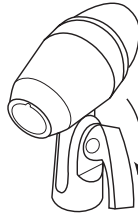

3

Note: To adjust the tension on the lever, pull it open and use a flat head screwdriver to tighten or loosen the bolt on the opposite side.

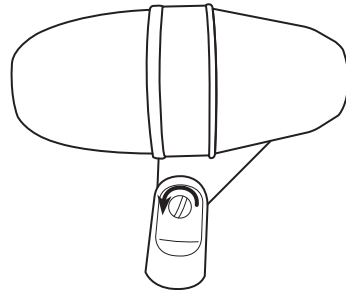

Optional Accessories and Replacement Parts

Microphone Clip for SM58, SM57, SM87A, Beta 87A, Beta 87C, PGA57, PGA58, PGA48, PGA81	A25D
Black Foam Windscreen for PGA81, SM94 and SM137	A3WS
7.6 m (25 ft.) Cable (XLR-XLR)	C25J
5/8" to 3/8" Thread Adapter	31A1856
Vinyl zippered storage bag	95B2324
Drum Microphone Mount	AP56DM
Grille	RPM154
PGA57 Replacement Grille	RPM152
PGA56 Replacement Grille	RPM152

Certifications

This product meets the Essential Requirements of all relevant European directives and is eligible for CE marking.

The CE Declaration of Conformity can be obtained from: www.shure.com/europe/compliance

Authorized European representative:
 Shure Europe GmbH
 Headquarters Europe, Middle East & Africa
 Department: EMEA Approval
 Jakob-Dieffenbacher-Str. 12
 75031 Eppingen, Germany
 Phone: 49-7262-92 49 0
 Fax: 49-7262-92 49 11 4
 Email: info@shure.de

Specifications

PGA52

Type

Dynamic (moving coil)

Frequency Response

50 to 12,000 Hz

Polar Pattern

Cardioid

Output Impedance

150 Ω

Sensitivity

at 1 kHz, open circuit voltage

-55 dBV/Pa¹ (1.75 mV)

Polarity

Positive pressure on diaphragm produces positive voltage on pin 2 with respect to pin 3

Weight

454 g (16.01oz.)

Connector

Three-pin professional audio (XLR), male

Environmental Conditions

Operating Temperature	-20° to 165°F (-29° to 74°C)
Relative Humidity	0 to 95%

1 Pa=94 dB SPL

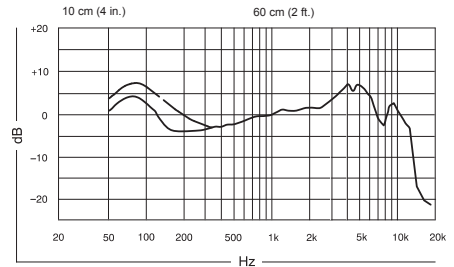

Typical Frequency Response

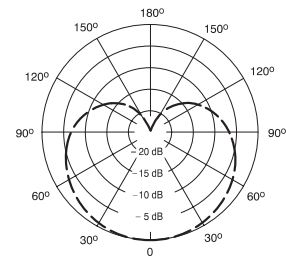

1000 Hz
 Typical Polar Pattern

PGA56

Type

Dynamic (moving coil)

Frequency Response

50 to 15,000 Hz

Polar Pattern

Cardioid

Output Impedance

200 Ω

Sensitivity

at 1 kHz, open circuit voltage

-57 dBV/Pa¹ (1.45 mV)

Polarity

Positive pressure on diaphragm produces positive voltage on pin 2 with respect to pin 3

Weight

287 g (10.12oz.)

Connector

Three-pin professional audio (XLR), male

Environmental Conditions

Operating Temperature	-20° to 165° F (-29° to 74° C)
Relative Humidity	0 to 95%

1 Pa=94 dB SPL

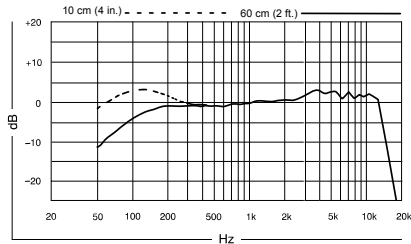

Typical Frequency Response

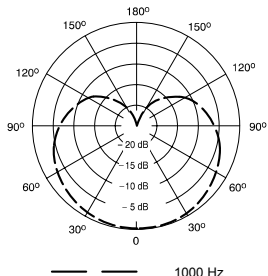

Typical Polar Pattern

PGA57

Type

Dynamic (moving coil)

Frequency Response

50 to 15,000 Hz

Polar Pattern

Cardioid

Output Impedance

150 Ω

Sensitivity

at 1 kHz, open circuit voltage

-56.5 dBV/Pa¹ (1.5 mV)

Polarity

Positive pressure on diaphragm produces positive voltage on pin 2 with respect to pin 3

Weight

280 g (9.88oz.)

Connector

Three-pin professional audio (XLR), male

Environmental Conditions

Operating Temperature	-20° to 165° F (-29° to 74° C)
Relative Humidity	0 to 95%

1 Pa=94 dB SPL

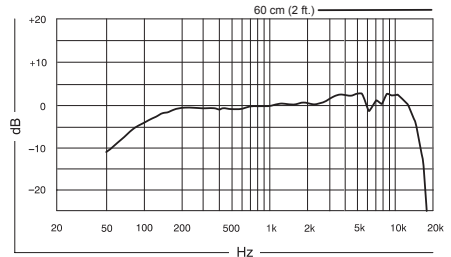

Typical Frequency Response

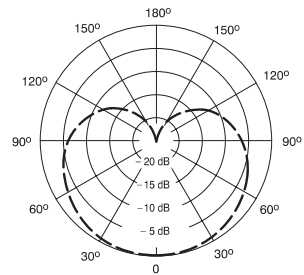

Typical Polar Pattern

PGA81

Type

Electret Condenser

Polar Pattern

Cardioid

Frequency Response

40 to 18,000 Hz

Output Impedance

at 1 kHz, open circuit voltage

600 Ω

Sensitivity

at 1 kHz, open circuit voltage

-48.5 dBV/Pa[1] (3.8 mV)

Maximum SPL

1 kHz at 1% THD, 1 k Ω load, typical

129.5 dB SPL

Polarity

Positive pressure on diaphragm produces positive voltage on pin 2 with respect to pin 3

Connector

Three-pin professional audio (XLR), male

Weight

186 g (0.4 lbs)

Housing

Cast Zinc

Power Requirements

48 V DC phantom power (2.0 mA)

[1] 1 Pa=94 dB SPL

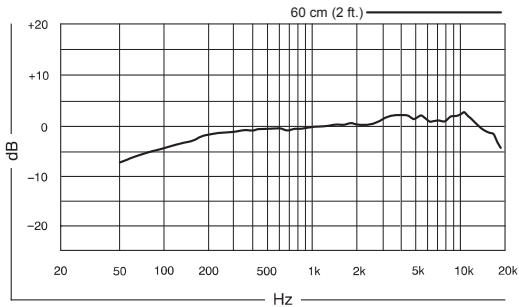

Frequency Response

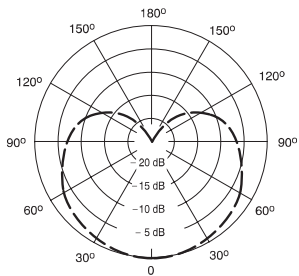

Polar Pattern

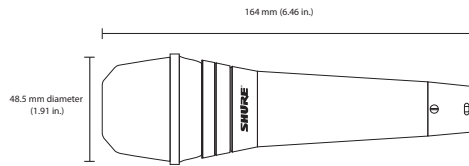
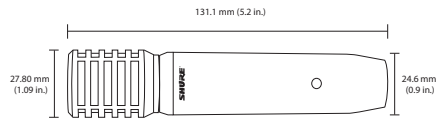
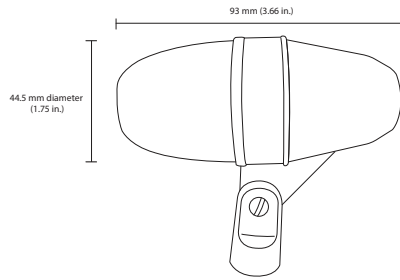
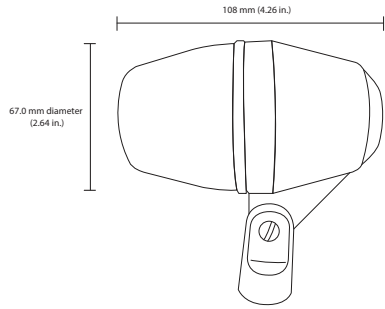

SHURE[®]
LEGENDARY
PERFORMANCE™

United States, Canada,
Latin America, Caribbean:
Shure Incorporated
5800 West Touhy Avenue
Niles, IL 60714-4608 USA

Phone: +1 847-600-2000
Fax: +1 847-600-1212 (USA)
Fax: +1 847-600-6446
Email: info@shure.com
www.shure.com

Europe, Middle East, Africa:
Shure Europe GmbH
Jakob-Dieffenbacher-Str. 12,
75031 Eppingen, Germany

Phone: +49-7262-92490
Fax: +49-7262-9249114
Email: info@shure.de
www.shure.eu

Asia, Pacific:
Shure Asia Limited
22/F, 625 King's Road
North Point, Island East
Hong Kong

Phone: +852-2893-4290
Fax: +852-2893-4055
Email: info@shure.com.hk
www.shureasia.com