

Beta 98AMP/C Condenser Drum Microphone (Cardioid)

Overview

The cardioid condenser microphone Beta 98AMP/C with integrated preamplifier, provides a smooth, natural, tailored response. It has an extremely high maximum SPL and wide dynamic range, ideal for drums and percussion. It offers a flexible gooseneck and the A75M universal microphone mount for accurate and secure placement in any configuration.

Features

- Uniform cardioid polar pattern provides maximum gain-before-feedback
- Rejection of off-axis sound for smooth high-end response and control
- Frequency response tailored for drums and percussion applications with a wide dynamic range for use in high SPL environments
- Precision-engineered design features integrated preamplifier and XLR connector
- Flexible gooseneck for precise placement and easy adjustment
- Ships with A75M universal microphone mount for secure placement

Specifications

| | |
|--|---|
| Type | Condenser (electret) |
| Frequency Response | 20 Hz to 20 kHz |
| Polar Pattern | Cardioid |
| Impedance | 150 Ω |
| Sensitivity (at 1 kHz, open circuit voltage) | -50.5 dBV/Pa (3 mV/Pa) |
| Maximum SPL (1 kHz at 1% THD) | 153 dB (1 kΩ load) 157.5 dB (2.5 kΩ load) |
| Signal-to-Noise Ratio (referenced at 94 dB SPL at 1 kHz) | 63.0 dB |
| Dynamic Range (at 1 kHz) | 122.0 dB (1 kΩ load) 126.5 dB (2.5 kΩ load) |
| Clipping Level (20 Hz-20 kHz at 1% THD) | 7.5 dBV (1 kΩ load) 12.5 dBV (2.5 kΩ load) |
| Self Noise (typical, equivalent SPL, A-weighted) | 31 dB(A) |
| Polarity | Positive pressure on diaphragm produces positive voltage on pin 2 with respect to pin 3 |
| Weight | 130 g |
| Connector | Three-pin professional audio (XLR), male |
| Power Requirements | 11 - 52 Vdc phantom, 3.6 mA |



Beta 98AMP/C

Accessories and Replacement Parts

| | | | | | |
|----------------|------------------------------|----------------|---------------------|----------------|-----------|
| A75M | Universal Microphone Mount* | 95A2314 | Storage Bag* | A75-57F | Mic Clip* |
| 95A2050 | 5/8" to 3/8" Thread Adapter* | 95A2064 | Snap-fit Windscreen | | |

* included in delivery

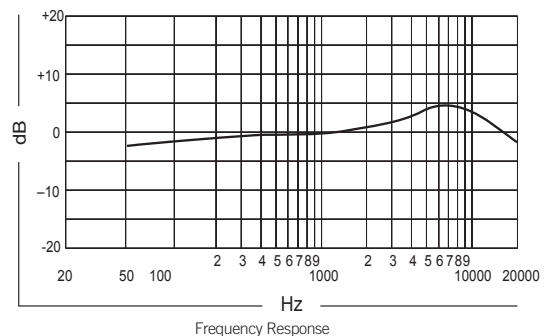
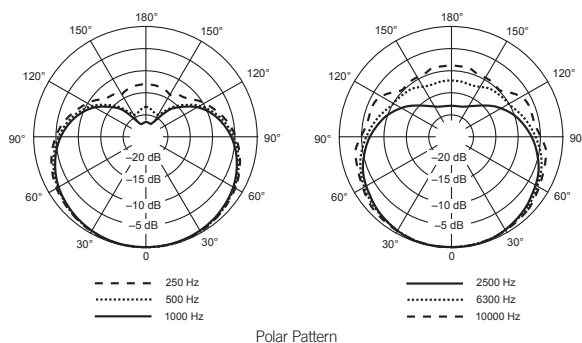

SHURE[®]
LEGENDARY
PERFORMANCE™