

# Product Specifications

## Beta® 98A Miniature Cardioid Condenser Microphone

### Overview

The Shure Beta 98A miniature cardioid condenser microphones are precision-engineered for professional drum and instrument in live and studio applications. The Beta 98AD/C is designed for use with toms, snares and percussion instruments in both sound reinforcement and recording applications. A flexible gooseneck mount allows for accurate placement in any configuration, customization for specific applications. The Beta 98A/C features a highly compact design which provides a variety of placement options for acoustic or amplified instruments including drums, piano, reed, wind, and strings.

### Features

- Uniform cardioid polar pattern provides maximum gain-before-feedback and rejection of off-axis sound for smooth high-end response and control
- Frequency response tailored for drums and percussion applications with a wide dynamic range for use in high SPL environments
- Precision-engineered design for unobtrusive microphone footprint
- Beta 98A models ship with external in-line preamplifier for discrete cable placement
- Beta 98AD/C ships with A98D Drum mount featuring a flexible gooseneck for precise placement and secure attachment
- Beta 98A/C ships with RK282 shock mount swivel adapter for attachment to any standard microphone stand
- Each model furnished with snap-fit windscreens and zipper pouch

### Available Models

<b>BETA 98AD/C</b>	Miniature Cardioid Condenser Drum Microphone
<b>BETA 98A/C</b>	Miniature Cardioid Condenser Microphone

### Specifications

Cartridge Type	Electret Condenser
Frequency Response	20 to 20,000 Hz
Polar Pattern	Cardioid
Output Impedance	179 Ω
Sensitivity (at 1 kHz, open circuit voltage)	-48.0 dBV/Pa (4.0 mV)
Maximum SPL (1 kHz at 1% THD, 1kΩ load)	144 dB
Signal-to-Noise Ratio (referenced at 94 dB SPL at 1 kHz)	64 dB <i>S/N ratio is difference between 94 dB SPL and equivalent SPL of self noise, A-weighted</i>
Dynamic Range (at 1 kHz, 1kΩ load)	114 dB
Clipping Level (1 kHz at 0.25% THD, 1kΩ load)	1.0 dBV (1.26 V)
Self-Noise (Typical, equivalent SPL, A-weighted)	30 dB SPL
Polarity	Positive pressure on diaphragm produces positive voltage on pin 2 with respect to pin 3
Weight	Net: 12 g (0.6 oz.)
Connector	Three-pin professional audio (XLR), male, balanced
Power Requirements	11–52 VDC phantom power (IEC-61938), 3.6 mA



Beta 98AD/C



Beta 98A/C

### Accessories and Replacement Parts

<b>RPM626</b>	In-Line Preamplifier	<b>95A2314</b>	Carrying/Storage Bag
<b>A98D</b>	Beta 98 Drum Mount (98D/S)	<b>C98D</b>	4.6 m (15 ft.) Heavy-Duty Cable (BETA 98D/S)
<b>RK282</b>	Shock-Mount Swivel Adapter (98D/S)	<b>95A2398</b>	7.6 m (25 ft.) light-weight cable (BETA 98/S)
<b>RK183WS</b>	Snap-fit Windscreens		

### Polar Pattern

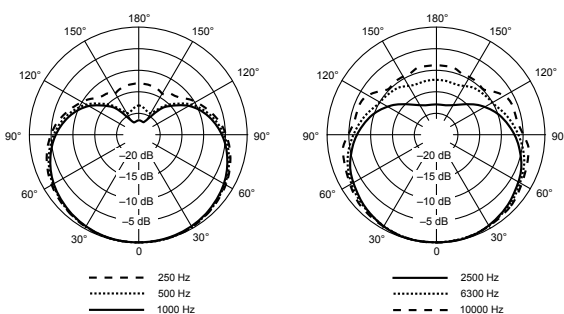

### Frequency Response

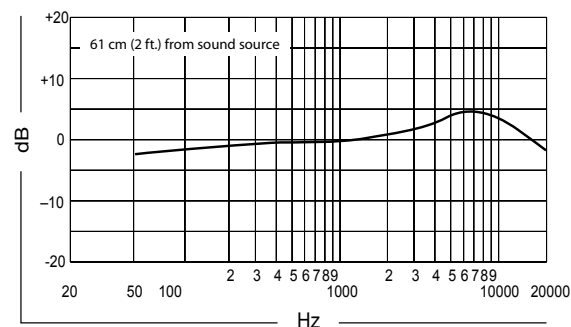

**SHURE**®

LEGENDARY  
PERFORMANCE™

www.shure.com

©2015 Shure Incorporated

### BETA 98A Instrument Microphone



#### General Description

The Shure Beta 98A is a compact, high-output, condenser microphone for professional sound reinforcement and studio recording. An extremely uniform cardioid polar pattern provides excellent gain before feedback and off-axis rejection of unwanted noise. Its high sound pressure level (SPL) capability makes it useful for a variety of acoustic or amplified instruments including drums, piano, reed, wind, and strings.

#### Variations

- **Beta 98A/C** includes microphone, 7.6 m (25 ft) light-weight interconnect cable, preamplifier, and RK282 shockmount swivel adapter.
- **Beta 98AD/C** includes microphone, 4.6 m (15 ft) heavy-duty interconnect cable, preamplifier, and A98D microphone drum mount.

#### Features

- Premier live performance microphone with Shure quality, ruggedness, and reliability
- Uniform cardioid pick-up pattern for maximum gain before feedback and superior rejection of off-axis sound
- Tailored frequency response specifically shaped for drums, percussion, reeds, and horns
- Compact design reduces stage clutter
- Wide dynamic range for use in high SPL environments
- Optional A98D mount is unobtrusive, versatile, and easy to adjust
- Enamel-coated metal construction and stainless steel inner grille resist wear and abuse

#### Performance Characteristics

- Exceptional low-frequency reproduction
- Extremely high SPL handling
- High output level
- No crossover distortion

#### Shockmount Swivel Adapter

Use the following procedures to mount the Beta 98A on the swivel adapter:

1. Connect the microphone to the adapter.
2. Thread the cable through the C-clamp and slide the connector into the C-clamp until snug.
3. To reduce wear on the cable, snap it into the stress reliever clip leaving 5 to 7 cm (2 to 3 inches) of slack on the connector side.

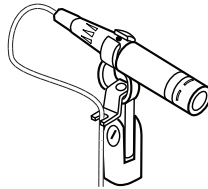

BETA 98A MOUNTED WITH SWIVEL ADAPTER

#### Interconnecting Cable

The supplied cable connects the BETA 98A to the preamplifier. If necessary, up to 23 m (75 ft) of cable can be used between the microphone and preamplifier without signal loss.

#### A98D Drum Mount

The Shure A98D mounts the Beta 98A on a drum or cymbal stand. Reference the furnished A98D guide to correctly mount the microphone.

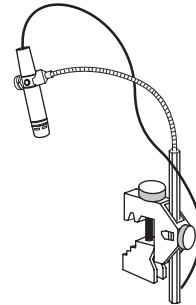

BETA 98A MOUNTED WITH A98D

#### Applications and Placement

##### General Rules for Use

- Aim the microphone toward the desired sound source; angle unwanted sounds toward its null point.
- Use the fewest amount of microphones as practical to increase the Potential Acoustic Gain and prevent feedback.
- Follow the 3 to 1 Rule by spacing each microphone by at least three times the distance to its source to reduce Phase Cancellation.
- Place microphones as far as possible from reflective surfaces to reduce Comb Filtering.
- When using directional microphones, work closely to the microphone for extra bass response to take advantage of Proximity Effect.
- Avoid excessive handling to minimize pickup of mechanical noise and vibration.
- Do not cover any part of the microphone grille, as this will adversely affect microphone performance.
- Add a windscreen when using the microphone outdoors.

## Load Impedance

Maximum SPL capability, output clipping level, and dynamic range vary with the input load impedance of the preamplifier to which you connect the microphone. Shure recommends a minimum input load impedance of 1000  $\Omega$ . Most modern microphone preamplifiers meet this requirement. Higher impedance results in better performance for these specifications.

## Power Requirements

This microphone requires phantom power and performs best with a 48 Vdc supply (IEC-61938). However, it will operate with slightly decreased headroom and sensitivity with supplies as low as 11 Vdc.

Most modern mixers provide phantom power. You must use a **balanced** microphone cable: XLR-to-XLR or XLR-to-TRS.

## SPECIFICATIONS

<b>Cartridge Type</b>	Electret Condenser	
<b>Polar Pattern</b>	Cardioid	
<b>Frequency Response</b>	20 to 20,000 Hz	
<b>Output Impedance</b> @ 1 kHz	179 $\Omega$	
<b>Sensitivity</b> open circuit voltage, @ 1 kHz, typical	-48.0 dBV/Pa <sup>[1]</sup> (4.0 mV)	
<b>Maximum SPL</b> 1 kHz at 1% THD <sup>[2]</sup>	2500 $\Omega$ load	150.5 dB
	1000 $\Omega$ load	144.0 dB
<b>Signal-to-Noise Ratio<sup>[3]</sup></b>	64 dB	
<b>Dynamic Range</b> @ 1 kHz	2500 $\Omega$ load	120.5 dB
	1000 $\Omega$ load	114.0 dB
<b>Clipping Level</b> 20 Hz to 20 kHz, 1% THD	2500 $\Omega$ load	8.0 dBV
	1000 $\Omega$ load	1.0 dBV
<b>Self Noise</b> equivalent SPL, A-weighted, typical	30.0 dB SPL-A	
<b>Connector</b>	Three-pin professional audio (XLR), male, balanced	
<b>Polarity</b>	Positive pressure on diaphragm produces positive voltage on pin 2 with respect to pin 3	
<b>Power Requirements</b>	11–52 V DC <sup>[4]</sup> phantom power (IEC-61938), 3.6 mA	
<b>Net Weight</b>	12 g (0.6 oz.)	

<sup>[1]</sup> 1 Pa=94 dB SPL

<sup>[2]</sup>THD of microphone preamplifier when applied input signal level is equivalent to cartridge output at specified SPL

<sup>[3]</sup>S/N ratio is the difference between 94 dB SPL and equivalent SPL of self noise, A-weighted

<sup>[4]</sup>All specifications measured with a 48 Vdc phantom power supply. The microphone operates at lower voltages, but with slightly decreased headroom and sensitivity.

## Accessories and Parts

### Furnished Accessories

Zippered Carrying Bag	95A2314
In-Line Preamplifier (1 piece)	RPM626
Snap-fit Windscreen	95A2064
Shock-Mount Swivel Adapter (BETA 98A/C)	RK282
7.6 m (25 ft.) light-weight cable (BETA 98A/C)	95A2398
Beta 98 Drum Mount (BETA 98AD/C)	A98D
4.6 m (15 ft.) Heavy-Duty Cable (BETA 98AD/C)	C98D

### Optional Accessories

Metal Locking Windscreen	A412MWS
Universal Microphone Mount	A75M

### Replacement Parts

Cardioid Cartridge	RPM98A/C
98A Replacement Housing	RPM98A-HT
Clamp Assembly (A98D)	RPM618
Snap-Fit Windscreen (4 per package)	RK183WS

## CERTIFICATION

Eligible to bear CE Marking. Conforms to European EMC Directive 2004/108/EC. Meets Harmonized Standards EN55103-1:1996 and EN55103-2:1996, for residential (E1) and light industrial (E2) environments.

The Declaration of Conformity can be obtained from:

Authorized European representative:  
Shure Europe GmbH  
Headquarters Europe, Middle East & Africa  
Department: EMEA Approval  
Wannenacker Str. 28  
D-74078 Heilbronn, Germany  
Phone: +49 7131 72 14 0  
Fax: +49 7131 72 14 14  
Email: EMEAsupport@shure.de

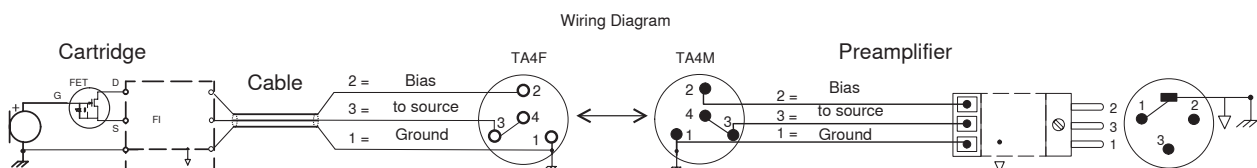

# Beta 98A

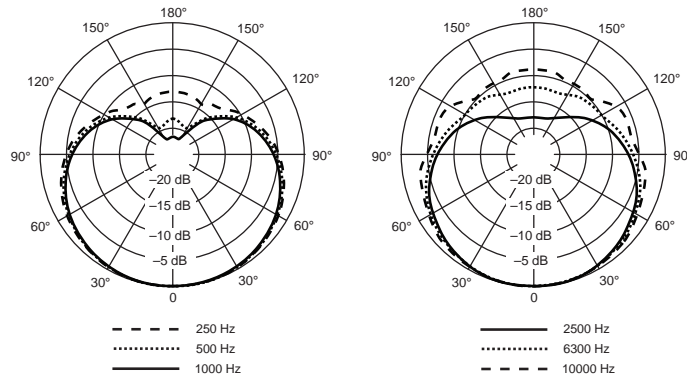
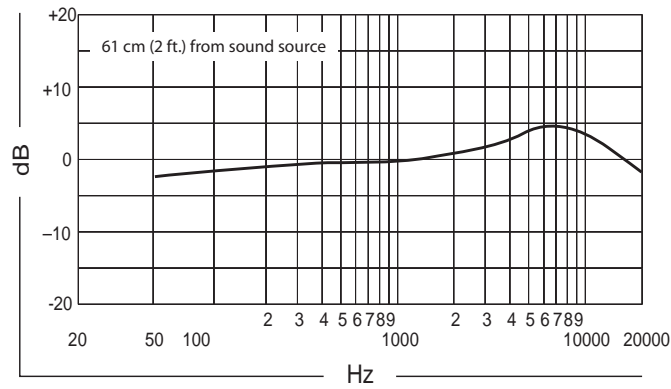

**United States, Canada, Latin America, Caribbean:**  
 Shure Incorporated  
 5800 West Touhy Avenue  
 Niles, IL 60714-4608 USA  
 Phone: 847-600-2000  
 Fax: 847-600-1212 (USA)  
 Fax: 847-600-6446  
 Email: info@shure.com

**Europe, Middle East, Africa:**  
 Shure Europe GmbH  
 Wannenäckestr. 28,  
 74078 Heilbronn, Germany  
 Phone: 49-7131-72140  
 Fax: 49-7131-721414  
 Email: info@shure.de

**Asia, Pacific:**  
 Shure Asia Limited  
 22/F, 625 King's Road  
 North Point, Island East  
 Hong Kong  
 Phone: 852-2893-4290  
 Fax: 852-2893-4055  
 Email: info@shure.com.hk