

# OPERA D

PROFESSIONAL ACTIVE SPEAKER

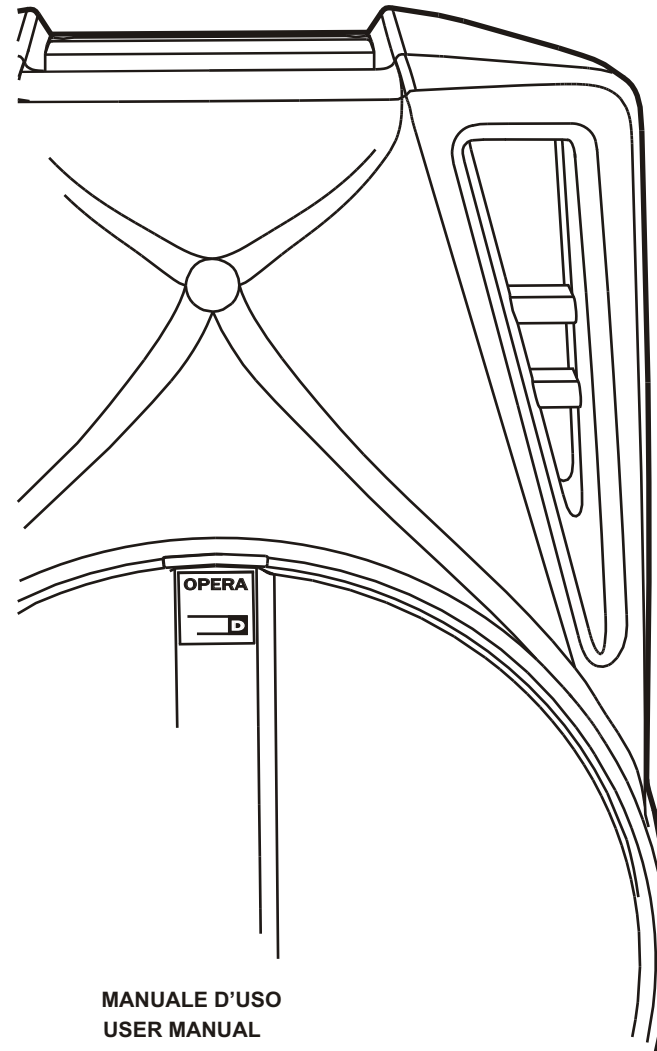

MANUALE D'USO  
USER MANUAL  
BEDIENUNGSANLEITUNG  
CARACTERISTIQUES TECHNIQUES



Made in Italy

COD. 420120167



A.E.B. INDUSTRIALE s.r.l.  
Via Brodolini, 8 - 40056 Crespellano (Bo) - ITALIA  
Tel. + 39 051 969870 - Fax. + 39 051 969725  
Internet: [www.dbtechnologies.com](http://www.dbtechnologies.com)  
E-mail: [info@dbtechnologies-aeb.com](mailto:info@dbtechnologies-aeb.com)

digipro®  
digital power

dB TECHNOLOGIES  
THE SOUND OF EXPERIENCE

**IMPORTANT SAFETY INSTRUCTIONS**

**CAUTION:** TO REDUCE THE RISK OF ELECTRICAL SHOCK, DO NOT REMOVE THE COVER (OR BACK). NO USER SERVICEABLE PARTS INSIDE; REFER SERVICING TO QUALIFIED PERSONNEL.

**WARNING:** TO REDUCE THE RISK OF FIRE OR ELECTRICAL SHOCK, DO NOT EXPOSE THIS APPLIANCE TO RAIN OR MOISTURE.



This symbol, wherever it appears, alerts you to the presence of uninsulated dangerous voltage inside the enclosure - voltage that may be sufficient to constitute a risk of shock.



This symbol wherever it appears, alerts you to important operating and maintenance instructions in the accompanying literature. Read the manual.

**IMPORTANT NOTES**

This manual is to be considered an integral part of the product, and must always accompany the equipment when it changes ownership, as a reference for correct installation and operation as well as for the safety regulations. The Manufacturing company will not assume any responsibility for incorrect installation of the amplifier.

**Read these instructions**

All the safety and operation instructions should be read before the appliance is operated.

**Heed all Warnings**

All warnings on the appliance and in the operating instructions should be adhered to

**Long period non use of equipment**

If long term non use of appliance is expected, it would be better to unplug this apparatus from power supply, put it into proper packaging and cover to avoid dust exposure.

**Damage and repair**

If apparatus has been damaged it is forbidden to repair it or to remove cover. Disconnect the unit from the mains power and contact technical assistance for repair.

**INSTALLATION AND OPERATING PRECAUTIONS****GENERAL****Keep these instructions**

For a correct use of the appliance, the safety and operating instructions should be retained for future reference.

**Apparatus positioning**

Make sure that the apparatus is positioned in a stable and secure way in order to avoid any dangerous conditions for persons or objects.

**Grounding protection**

The apparatus is made in protection CLASS I to prevent the risk of electrical shock the appliance must be connected to a mains socket outlet with a protective earthing connection. Before making the electrical connection of the appliance, ensure that the electrical distribution network conforms to the regulations regarding electrical equipment.

**Power Source**

The appliance should be connected to a power supply only of the type described in the operating instructions or as marked on the appliance (see "Specifications"). In order not to jeopardize the safety of the amplifier, it must only be connected to the mains using the power cable provided.

**Power Cord Protection**

To ensure a safe use of appliance, use only the power cord supplied with the equipment, taking care to place it and protect it to avoid damage during use. If power cord becomes damaged contact technical assistance and request replacement. Do not use cables other than supplied cables.

**Water and Moisture**

Do not install this apparatus near water (e.g. near washbasins, sinks, showers, bathtubs, swimming pool, wet floors or anything in the presence of water and liquids in general).

**Object and Liquid Entry**

The apparatus must be placed in inappropriate position. Care should be taken so that objects do not fall and liquids are not spilled into the enclosure through cooling grid with consequent electrical danger.

**Ventilation**

The appliance should be situated so that its location or position does not interfere with its proper ventilation. Do not block or cover any openings of the grid ventilation or heatsink. Install the apparatus at a distance that ensures a good ventilation between devices.

**Heat**

Do not install the appliance near any source of heat.

**Accessories and installation**

For a safe installation, do not make any holes in the external chassis for the application of additional brackets. In case of particular installations not described in this manual, contact technical service for accessories specified by the manufacturer.

**Follow the instructions**

All operations and instructions in this user manual should be followed for a correct operation and function of appliance. Pay attention in particular to:

- Never force the control elements (switches, controls, etc.).
- Do not force the amplifier to work in overload for extended periods of time.

**Cleaning**

Clean only with a dry cloth. Do not use solvents, alcohol, benzene or volatile substances for cleaning the exterior parts.

**CONNECTION****CAUTION**

- For connecting the appliance, use only qualified and experienced personnel having sufficient technical knowledge or specific instructions for making the connections correctly and thus preventing electrical dangers.
- To prevent the risk of electrical shock, the appliance must only be supplied from the mains after all connections have been completed.
- Before powering up the appliance, it is advisable to re-check all the connections.
- The entire sound system must be designed and installed in compliance with the current standards and regulations regarding electrical systems.

**SUGGESTIONS****CAUTION**

To prevent inductive phenomena from giving rise to hum or disturbance which would jeopardize efficient appliance operation, the cables that transmit microphone signals or line level signals (e.g. 0 dB/V) must be screened and should not be run in the vicinity of:

- 1) Equipment that produces strong magnetic fields (e.g. large power supply transformers)
- 2) Electrical energy conductors
- 3) Lines that supply speakers.

This device complies with European Directives 2006/95/EC and 2004/108/EC and is provided with CE marking.

The respective declaration of conformity is available in AEB Industriale s.r.l.

**EMI CLASSIFICATION**

According to the standards EN 55103 this equipment is designed and suitable to operate in E3 (or lower E2, E1) Electromagnetic environments.

**DESCRIPTION**

The models of the "OPERA D" series use cutting edge digital amplifiers of the DIGIPRO® series, providing three different powers - 200W, 400W, and 600W - to meet the requirements of any kind of application.

These highly efficient amplifiers provide high power with limited weight and dimension. Thanks to the low power dissipated, the cooling of the amplifier module does not require a fan.

The digital preamplifier with DSP (Digital Signal Processing) controls the audio crossover of the acoustic components, the frequency response, the limiter, and the phase alignment. A selector enables to select one of two different equalizations - "FLAT" or "PROCESSED" - to provide high versatility for the different applications.

The amplifiers DIGIPRO® 400W e 600W use power supplies featuring SMPS (Switched-Mode Power Supplies) technology.

This technology increases power supply efficiency and minimizes its weight.

The correct operation is signalled by the lighting of a blue indicator, located on the front panel of the speaker. The indicator can be disabled following a specific procedure described in paragraph "Front LED" (Page 20).

**OPERA 208D**

The OPERA 208D bi-amped active speaker is equipped with a DIGIPRO® amplifier delivering 150W RMS for the bass section and 50W RMS for the high frequency section.

The 2-way bi-amplified speaker is equipped with 8" woofer (1,5" voice coil) and 1" Neodymium driver (1" voice coil) loaded with 80°/65°x60° asymmetric horn.

The speaker is in plastic material, provided with recessed top handle, easing its transport.

In the bottom of the box there is a standard pole mount cup (D36mm).

The speaker has been designed to be used also as stage monitor (43° angle).

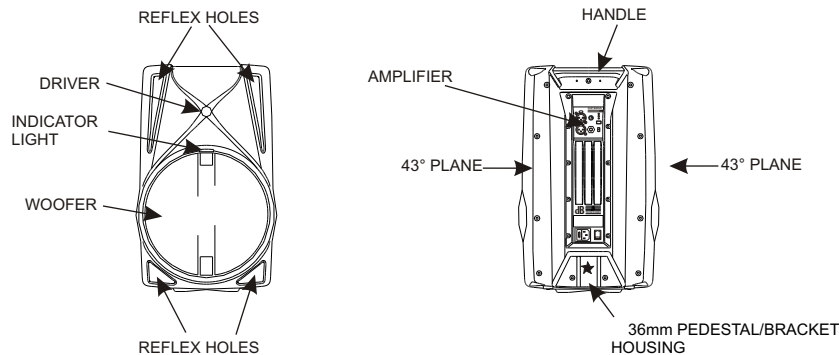
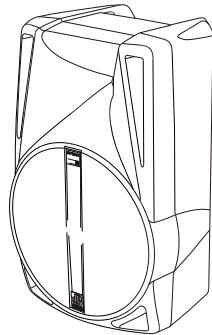
**OPERA 210D**

The OPERA 210D bi-amped active speaker is equipped with a DIGIPRO® amplifier delivering 150W RMS for the bass section and 50W RMS for the high frequency section.

The 2-way bi-amplified speaker is equipped with 10" woofer (1,5" voice coil) and 1" Neodymium driver (1" voice coil) loaded with 80°/65°x60° asymmetric horn.

The speaker is plastic material and is provided with top handle, rubber coated, easing its transport

In the bottom of the box there is a standard pole mount cup (D36mm).

The speaker has been designed to be used also as stage monitor (43° angle).

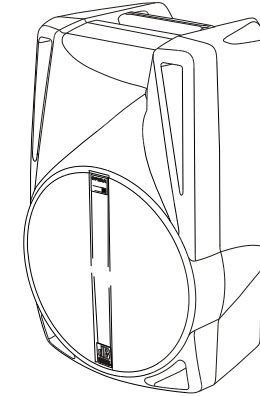
**OPERA 410D**

The OPERA 410D bi-amped active speaker is equipped with a DIGIPRO® amplifier delivering 300W RMS for the bass section and 100W RMS for the high frequency section.

The 2-way bi-amplified speaker is equipped with 10" woofer (2" voice coil) and 1" compression driver (1.3" voice coil) loaded with 80°/65°x60° asymmetric horn.

The speaker is plastic material and is provided with top handle, rubber coated, easing its transport

In the bottom of the box there is a standard pole mount cup (D36mm).

The speaker has been designed to be used also as stage monitor (43° angle).

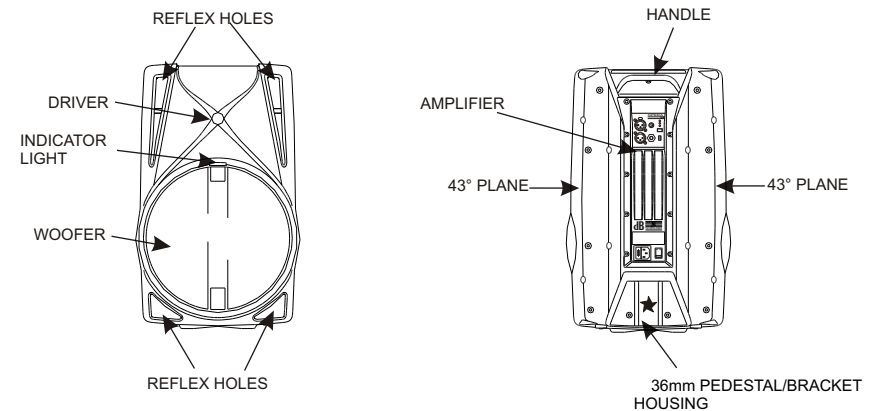

**OPERA 402D**

The OPERA 402D bi-amped active speaker is equipped with a DIGIPRO® amplifier delivering 300W RMS for the bass section and 100W RMS for the high frequency section.

The 2-way bi-amplified speaker is equipped with 12" woofer (2" voice coil) and 1" compression driver (1.5" voice coil) loaded with 80°/65°x60° asymmetric horn.

The speaker is plastic material and is provided with top handle and two rubber coated side handles, easing its transport.

In the bottom of the box there is a standard pole mount cup (D36mm).

The speaker has been designed to be used also as stage monitor (43° angle).

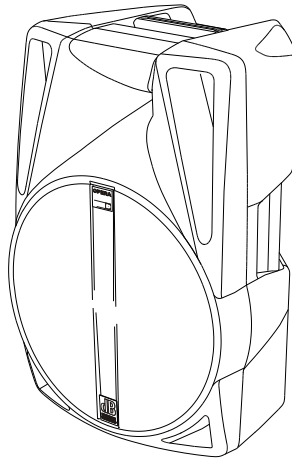
**OPERA 405D**

The OPERA 405D bi-amped active speaker is equipped with a DIGIPRO® amplifier delivering 300W RMS for the bass section and 100W RMS for the high frequency section.

The 2-way bi-amplified speaker is equipped with 15" woofer (2" voice coil) and 1" compression driver (1.5" voice coil) loaded with 80°/65°x60° asymmetric horn.

The speaker is plastic material and is provided with top handle and two rubber coated side handles, easing its transport.

In the bottom of the box there is a standard pole mount cup (D36mm).

The speaker has been designed to be used also as stage monitor (43° angle).

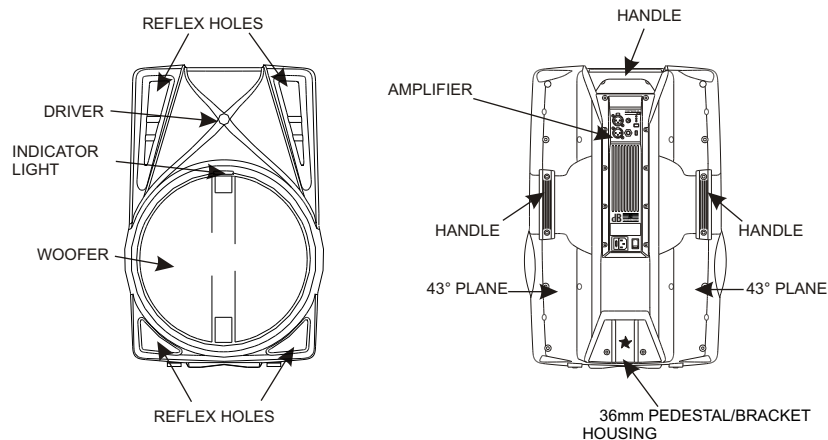
**OPERA 602D**

The OPERA 602D bi-amped active speaker is equipped with a DIGIPRO® amplifier delivering 400W RMS for the bass section and 200W RMS for the high frequency section.

The 2-way bi-amplified speaker is equipped with 12" Neodimio woofer (3" voice coil) and 1" compression driver (1.75" voice coil) loaded with 80°/65°x60° asymmetric horn.

The speaker is plastic material and is provided with top handle and two rubber coated side handles, easing its transport.

In the bottom of the box there is a standard pole mount cup (D36mm).

The speaker has been designed to be used also as stage monitor (43° angle).

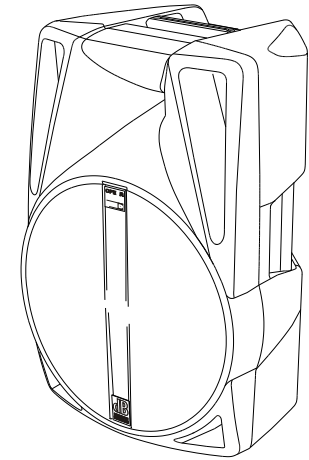
**OPERA 605D**

The OPERA 605D bi-amped active speaker is equipped with a DIGIPRO® amplifier delivering 400W RMS for the bass section and 200W RMS for the high frequency section.

The 2-way bi-amplified speaker is equipped with 15" Neodimio woofer (3" voice coil) and 1" compression driver (1.75" voice coil) loaded with 80°/65°x60° asymmetric horn.

The speaker is plastic material and is provided with top handle and two rubber coated side handles, easing its transport.

In the bottom of the box there is a standard pole mount cup (D36mm).

The speaker has been designed to be used also as stage monitor (43° angle).

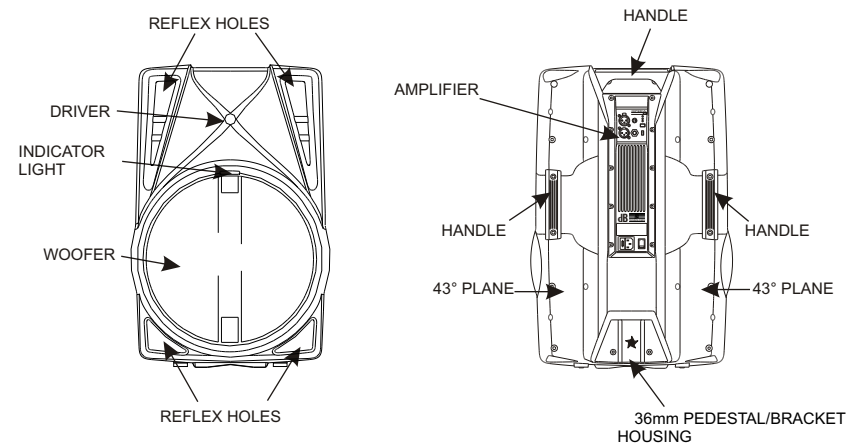

## COMMANDS AND FUNCTIONS

### AMPLIFIER PANEL

- 1) **“Balanced Input” - “Link” - “Input Link” CONNECTORS**  
These balanced inputs can be used to connect balanced or unbalanced microphones or audio sources at line level (0dB) (eg. preamplifier, mixer, recorder, CD player, musical instrument, ...).  
The balanced connector is connected in parallel and can be used to send the audio signal to other amplified speakers, recorders or supplementary amplifiers.
- 2) **“Limiter” INDICATOR LIGHT**  
This indicator shows red to indicate that the internal limiter circuit has tripped.  
This prevents amplifier distortion and protects the speakers against overloads.
- 3) **“Signal” INDICATOR LIGHT**  
This indicator shows green to indicate the presence of the audio signal (at a level of -20dB).
- 4) **“Ready” INDICATOR LIGHT**  
This indicator shows green to indicate that the main power voltage is correct.  
The LED shows green normal operating conditions
- 5) **“Sensitivity” INPUT SENSITIVITY CONTROL**  
This control adjusts the sensitivity of the signal amplifier input.  
This control does not affect the “Link” - “Input - Link” output level
- 6) **MODE SWITCH**  
This two-way switch allows to choose between two different system presets.  
The “Flat” position allows linear response of the speaker, which is mainly suitable for the “live” application.  
The “Processed” position emphasizes the low frequency and regulates the mid frequency. It is suitable for music play back
- 7) **“Input Sens” SWITCH**  
Position the switch in LINE to use a line level source (0 dB) or MIC to use a microphone.
- 8) **POWER CABLE SOCKET “MAINS”**  
Used for connecting the power cable supplied.
- 9) **FUSE CARRIER “FUSE”**  
Mains fuse housing.
- 10) **POWER SWITCH “POWER”**  
This switch can be used to switch the diffuser on and off.

### SPEAKER FRONT

- 1) **INDICATOR LIGHT**  
The blue indicator light indicates speaker status

## CHARACTERISTICS AND PROTECTION

### Front Grille

The speakers's components in the box are protected by 1.2mm metal steel grille (8" version) and by 1.5mm metal steel grille(10",12" and 15" versions) covered by foam on backside.

### Cooling

Thermal control is provided by the internal microprocessor which, by means of two sensors, controls the temperature of the amplifier and of the power supply, avoiding overheating by limiting the overall volume.

In case of overheating (> 80 degrees) the volume decreases proportionally to the temperature increase, making the change unnoticeable.

The correct volume and all the functions are automatically restored when standard operating temperatures are reached.

### Front LED

On the front of the speaker a blue LED indicates the state of the speaker.

During normal operation the speaker front LED can be disabled if necessary (theatre, cinema installations)

To change the state of the front LED, press and release for several times (6 times) the MODE switch during switch on, when all the LEDs (“Limiter”, “Signal” and “Ready”) on the amplifier module are off.

To restore front LED operation, repeat the operation.

The diagnostics of the speaker provided by this LED, is still active even if the LED is disabled.

### Switch on

The amplifiers are equipped with a microprocessor to control the DSP and the amplifier.

The correct switch on of the amplifier is ensured by an initialization procedure; during this test stage, the blue front LED flashes twice and the LEDs (“Limiter”, “Signal” and “Ready”), located on the amplifier module, remain off for approx. 2 sec.

At the end of the switch on procedure, the front LED lights up (if enabled) and on the amplifier module the “Ready” green LED only remains steadily on.

In case of severe failure of the speaker, the LED on the front panel flashes several times and on the amplifier module, the “Limiter” red LED flashes.

The speaker switches to “mute”.

### Failure indications and safeties

The microprocessor is able to signal three different kinds of failure by flashing the “Limiter” red LED on the amplifier panel before the lighting up of the “Ready” green LED. The three types of failure are:

- 1) **WARNING:** a non severe error or auto-ripristinate malfunction is detected and the performance of the speaker is not limited
- 2) **LIMITATION:** an error is detected and the performance of the speaker is limited (the sound level is reduced by 3dB).  
This does not affect the operation of the speaker since it continues to operate. However, it is necessary to call the service centre to solve the issue.
- 3) **FAILURE:** a severe malfunction is detected. The speaker switches to “mute”.

Flashing	Indication
1 or 2	Warning
3 or 4	Limitation
from 5 to 8	Failure

In case of failure, the “Ready” green LED remains off.

Perform the checks listed below:

- Check if the speaker is properly connected to the power supply.
- Make sure that the power supply is of correct voltage.
- Check that the amplifier is not overheated.
- Disconnect the speaker from the mains power supply, wait for a few minutes and connect it again.

If after these tests the red "LIMITER" LED is still on, please contact an authorised service centre.

## LOUDSPEAKER INSTALLATION



### WARNING

Make sure that the loudspeaker is securely installed in a stable position to avoid any injuries or damages to persons or property.

For safety reasons do not place one loudspeaker on top of another without proper fastening systems. Before hanging the loudspeaker check all the components for damages, deformations, missing or damaged parts that may compromise safety during installation.

If you use the loudspeakers outdoors avoid places that are exposed to bad weather.

The loudspeaker has the following mounting options:

- bookshelf (Fig. 1)
- floor (monitor) (Fig.2)
- on speaker stands (Fig.3)
- suspended with brackets supplied by the manufacturer (Fig.4)



### WARNING

Never use the handles to hang the speaker!

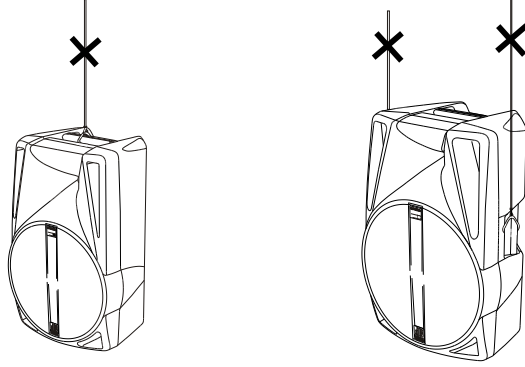

## TECHNICAL SPECIFICATIONS

### Amp and processor

Power supply:  
 HF amp:  
 Bass amp:  
 Cooling:  
 System presets:  
 Limiter:  
 Pre-Amp:  
 X-over frequency:

### Audio Data

Frequency response -10 dB:  
 Frequency response +3 dB:  
 Max SPL:  
 Bass/midrange woofer:  
 High frequency driver:  
 Horn:

### Input section

Signal input/link:

Input sensitivity:  
 Mains:

### Hardware

Pole mount:  
 Handles:  
 Angles up:  
 Grille:  
 Dimensions (W x H x D):  
 Weight:  
 Optional accessories:

### OPERA 210D

Analog  
 Class-D 50 W/RMS  
 Class-D 150 W/RMS  
 Convection, fan-free  
 Flat, Processed  
 Peak,RMS, Thermal, limiters  
 24bit 48KHz DSP  
 2050 Hz, 24 dB/oct.

62 Hz - 20 kHz  
 71 Hz - 19 kHz  
 122 dB  
 1x10" - 1,5" voice coil  
 1x1" driver Neodymium  
 80°/65 x 60° CD Horn

XLR fem. Balanced  
 XLR male balanced  
 6,3mm JACK balanced  
 -40dBu/-3dBu (Mic/Line)  
 IEC, VDE

36mm  
 one on top (rubber)  
 43° for monitor  
 1,5mmmm Metal with foam  
 343 x 553 x 304 mm  
 9,8 kg  
 gig bag, mounting bracket

### OPERA 410 D

SMPS  
 Class-D 100 W/RMS  
 Class-D 300 W/RMS  
 Convection, fan-free  
 Flat, Processed  
 Peak,RMS, Thermal, limiters  
 24bit 48KHz DSP  
 1940 Hz, 24 dB/ oct

61 Hz - 20 kHz  
 70 Hz - 19 kHz  
 127 dB  
 1x10 - 2", voice coil  
 1x1" Compression driver 1,3" voice coil  
 80°/65 x 60° CD Horn

XLR fem. Balanced  
 XLR male balanced  
 6,3mm JACK balanced  
 -40dBu/-3dBu (Mic/Line)  
 IEC, VDE

36mm  
 one on top (rubber)  
 43° for monitor  
 1,5mmmm Metal with foam  
 343 x 553 x 304 mm  
 10,6 kg  
 gig bag, mounting bracket

**TECHNICAL SPECIFICATION****Amp and processor**

Power supply: SMPS  
 HF amp: Class-D 100 W/RMS  
 Bass amp: Class-D 300 W/RMS  
 Cooling: Convection, fan-free  
 System presets: Flat, Processed  
 Limiter: Peak,RMS, Thermal, limiters  
 Pre-Amp: 24bit 48KHz DSP  
 X-over frequency: 1870Hz, 24 dB/oct.

**Audio Data**

Frequency response -10 dB: 59 Hz - 20 kHz  
 Frequency response +3 dB: 70 Hz - 19 kHz  
 Max SPL: 128 dB  
 Bass/midrange woofer: 1x12" - 2", voice coil  
 High frequency driver: 1x1" compression driver - 1,5" voice coil  
 Horn: 80°/65 x 60° CD Horn

**Input section**

Signal input/link: XLR fem. Balanced  
 XLR male balanced  
 6,3mm JACK balanced  
 -40dBu/-3dBu (Mic/Line)  
 IEC, VDE  
 Input sensitivity: 36 mm  
 Mains: two on side (with rubber)  
 One on top (with rubber)  
 43° for monitor  
 1,5mmmm Metallica with foam  
 432 x 655 x 353mm  
 14,1 kg  
 gig bag, mounting bracket

**Hardware**

Pole mount: 36mm  
 Handles: two on side (with rubber)  
 one on top (with rubber)  
 43° for monitor  
 1,5mmmm Metallica with foam  
 432 x 655 x 353mm  
 14,5 kg  
 gig bag, mounting bracket  
 Angles up: 36mm  
 Grille: two on side (with rubber)  
 one on top (with rubber)  
 43° for monitor  
 1,5mmmm Metallica with foam  
 432 x 655 x 353mm  
 14,5 kg  
 gig bag, mounting bracket  
 Dimensions (W x H x D): 432 x 655 x 353mm  
 Weight: 14,1 kg  
 Optional accessories: gig bag, mounting bracket

**OPERA 402 D**

SMPS  
 Class-D 100 W/RMS  
 Class-D 300 W/RMS  
 Convection, fan-free  
 Flat, Processed  
 Peak,RMS, Thermal, limiters  
 24bit 48KHz DSP  
 1870Hz, 24 dB/oct.

59 Hz - 20 kHz  
 70 Hz - 19 kHz  
 128 dB  
 1x12" - 2", voice coil  
 1x1" compression driver - 1,5" voice coil  
 80°/65 x 60° CD Horn

XLR fem. Balanced  
 XLR male balanced  
 6,3mm JACK balanced  
 -40dBu/-3dBu (Mic/Line)  
 IEC, VDE

36 mm  
 two on side (with rubber)  
 One on top (with rubber)  
 43° for monitor  
 1,5mmmm Metallica with foam  
 432 x 655 x 353mm  
 14,1 kg  
 gig bag, mounting bracket

**OPERA 405 D**

SMPS  
 Class-D 300 W/RMS  
 Flat, Processed  
 1850 Hz, 24 dB/ oct.

49 Hz - 20 kHz  
 58 Hz - 19 kHz  
 129 dB  
 1x15" - 2" voice coil  
 1x1" compression driver - 1,5" voice coil  
 80°/65 x 60° CD Horn

XLR fem. Balanced  
 XLR male balanced  
 6,3mm JACK balanced  
 -40dBu/-3dBu (Mic/Line)  
 IEC, VDE

36mm  
 two on side (with rubber)  
 one on top (with rubber)  
 43° for monitor  
 1,5mmmm Metallica with foam  
 432 x 655 x 353mm  
 14,5 kg  
 gig bag, mounting bracket

**TECHNICAL SPECIFICATION****Amp and processor**

Power supply: SMPS  
 HF amp: Class-D 200 W/RMS  
 Bass amp: Class-D 400 W/RMS  
 Cooling: Convection, fan-free  
 System presets: Flat, Processed  
 Limiter: Peak,RMS, Thermal, limiters  
 Pre-Amp: 24bit 48KHz DSP  
 X-over frequency: 1690 Hz, 24 dB/oct.

**Audio Data**

Frequency response -10 dB: 58 Hz - 20 kHz  
 Frequency response +3 dB: 68 Hz - 19 kHz  
 Max SPL: 129 dB  
 Bass/midrange woofer: 1x12" - 3" voice coil Neodymium  
 High frequency driver: 1x1" compression driver (RCF ND350)  
 1,75" voice coil Neodymium  
 80°/65 x 60° CD Horn

**Horn:**

80°/65 x 60° CD Horn

**Input section**

Signal input/link: XLR fem. Balanced  
 XLR male balanced  
 6,3mm JACK balanced  
 -40dBu/-3dBu (Mic/Line)  
 IEC, VDE  
 Input sensitivity: 36 mm  
 Mains: two on side (with rubber)  
 one on top (with rubber)  
 43° for monitor  
 1,5mmmm Metal with foam  
 432 x 655 x 353mm  
 12,4 kg  
 gig bag, mounting bracket

**Hardware**

Pole mount: 36 mm  
 Handles (rubber): two on side (with rubber)  
 one on top (with rubber)  
 43° for monitor  
 1,5mmmm Metal with foam  
 432 x 655 x 353mm  
 12,4 kg  
 Optional accessories: gig bag, mounting bracket

**OPERA 602 D**

SMPS  
 Class-D 200 W/RMS  
 Class-D 400 W/RMS  
 Convection, fan-free  
 Flat, Processed  
 Peak,RMS, Thermal, limiters  
 24bit 48KHz DSP  
 1690 Hz, 24 dB/oct.

58 Hz - 20 kHz  
 68 Hz - 19 kHz  
 129 dB

1x12" - 3" voice coil Neodymium  
 1x1" compression driver (RCF ND350)  
 1,75" voice coil Neodymium  
 80°/65 x 60° CD Horn

XLR fem. Balanced  
 XLR male balanced  
 6,3mm JACK balanced  
 -40dBu/-3dBu (Mic/Line)  
 IEC, VDE

36 mm  
 two on side (with rubber)  
 one on top (with rubber)  
 43° for monitor  
 1,5mmmm Metal with foam  
 432 x 655 x 353mm  
 12,4 kg  
 gig bag, mounting bracket

**OPERA 605 D**

SMPS  
 Class-D 200 W/RMS  
 Class-D 400 W/RMS  
 Convection, fan-free  
 Flat, Processed  
 Peak,RMS, Thermal, limiters  
 24bit 48KHz DSP  
 1670 Hz, 24 dB/ oct.

48 Hz - 20 kHz  
 59 Hz - 19 kHz  
 130 dB

1x15" - 3" voice coil Neodymium  
 1x1" compression driver (RCF Nd350) Neodymium  
 1,75" voice coil Neodymium  
 80°/65 x 60° CD Horn

XLR fem. Balanced  
 XLR male balanced  
 6,3mm JACK balanced  
 -40dBu/-3dBu (Mic/Line)  
 IEC, VDE

36mm  
 two on side (with rubber)  
 one on top (with rubber)  
 43° for monitor  
 1,5mmmm Metal with foam  
 432 x 655 x 353mm  
 12,9 kg  
 gig bag, mounting bracket

OPERA 208D  
OPERA 210D

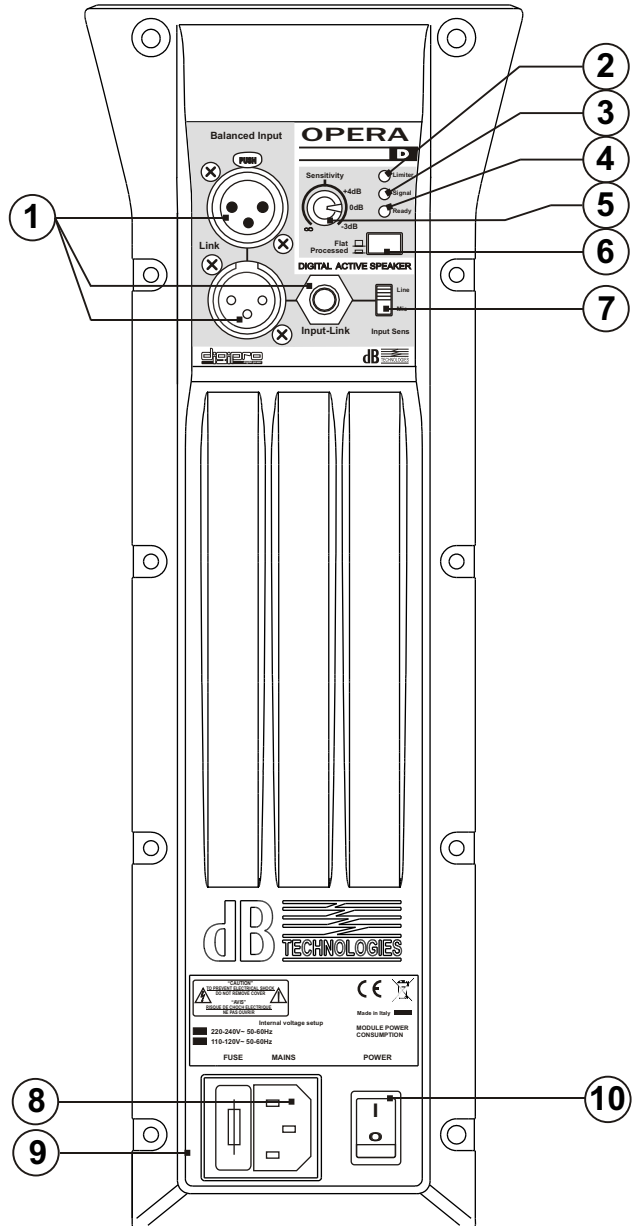

OPERA 410D - OPERA 402D - OPERA 405D  
OPERA 602D - OPERA 605D

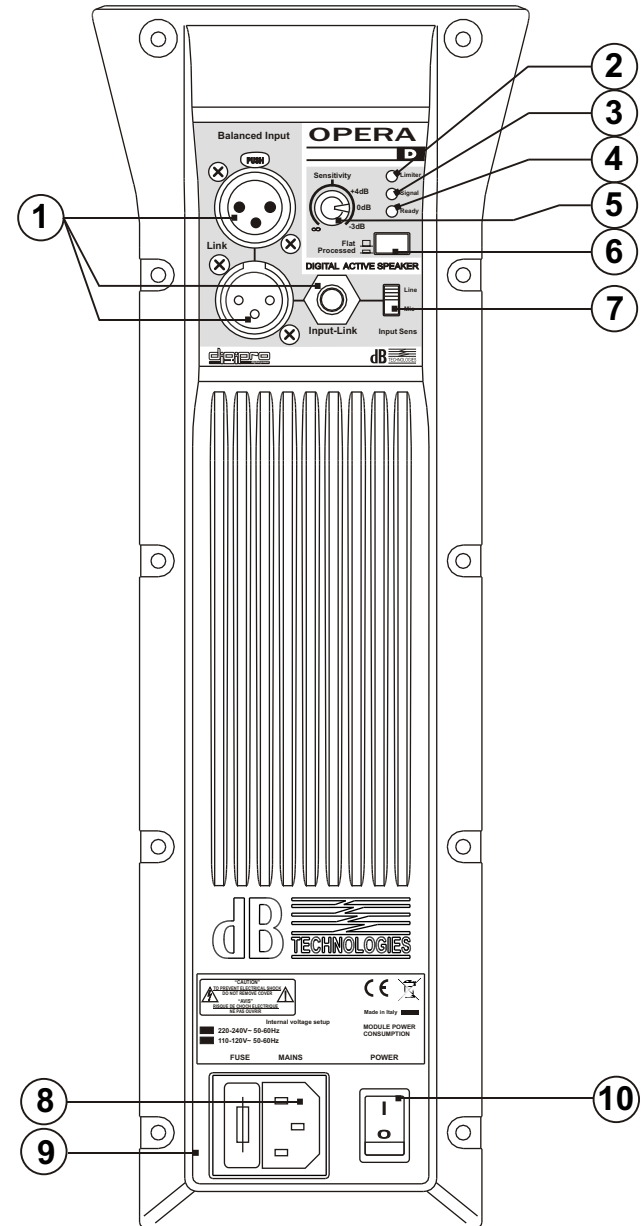



DIMENSIONI / DIMENSIONS  
 ABMESSUNGEN / DIMENSIONS

**OPERA 208D**

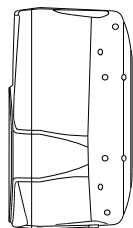
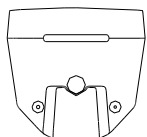
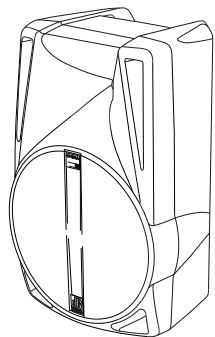

284

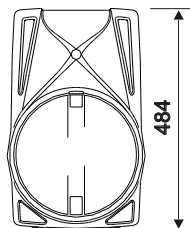

300

484

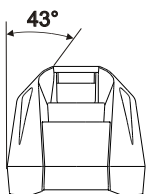

43°

**OPERA 210D  
 OPERA 410D**

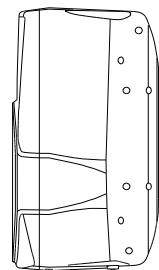
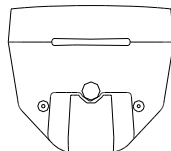
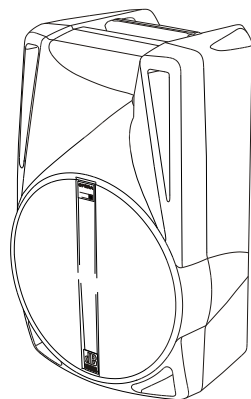

304

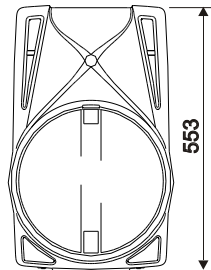

343

553

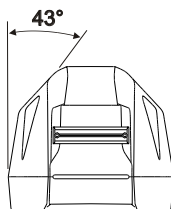

43°

DIMENSIONI / DIMENSIONS  
 ABMESSUNGEN / DIMENSIONS

**OPERA 402D  
 OPERA 405D  
 OPERA 602D  
 OPERA 605D**

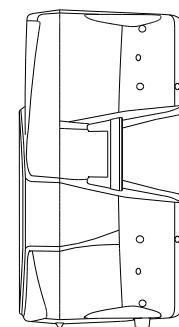
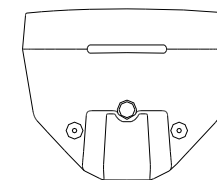
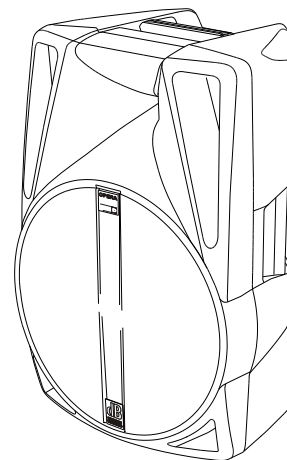

353

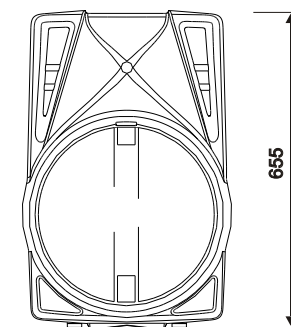

432

655

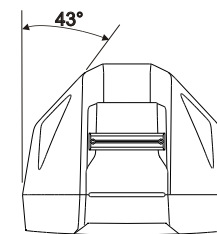

43°

ANGOLO DI COPERTURA TROMBA / HORN ANGLE COVERED  
HOCHTONHORN ABSTRAHLWINKEL / ANGLE DE COUVERTURE COTÉ

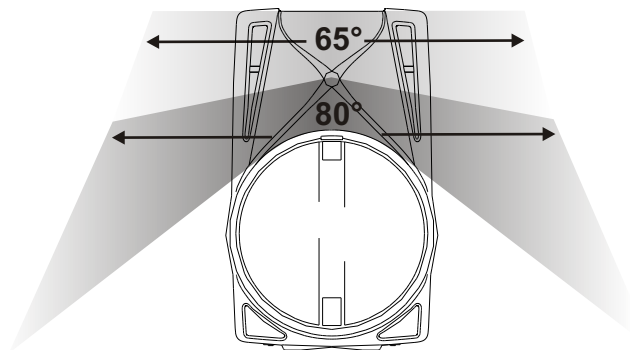
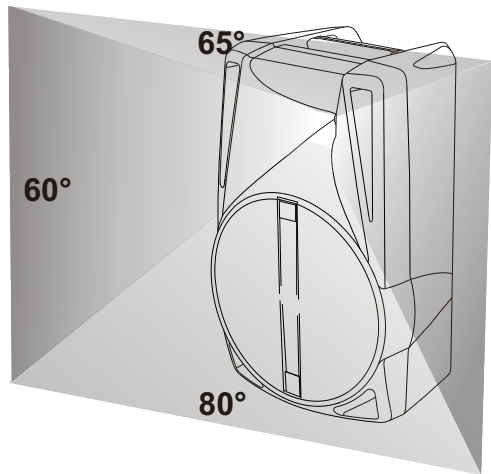

Long trough

Near field

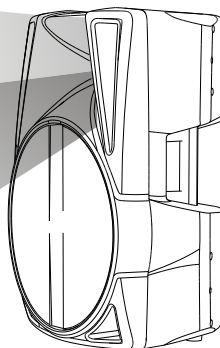

SCHEMA A BLOCCHI - BLOCK DIAGRAM  
BLOCKSCHALTBIID - SCHEMAS FONCTIONNELS

OPERA 208D  
OPERA 210D

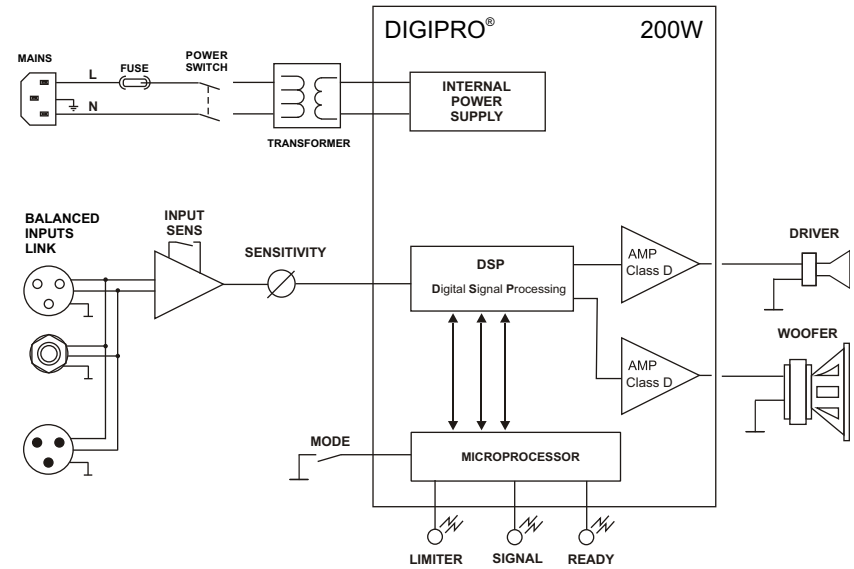

OPERA 410D OPERA 402D OPERA 405D  
OPERA 602D OPERA 605D

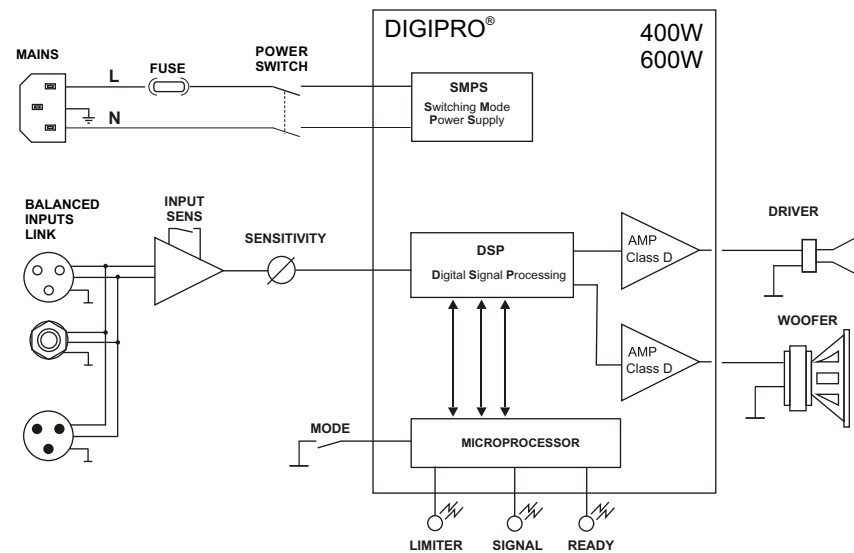

UTILIZZO IN APPOGGIO  
SUPPORTED USE  
ANWENDUNG  
UTILISATION EN APPUI

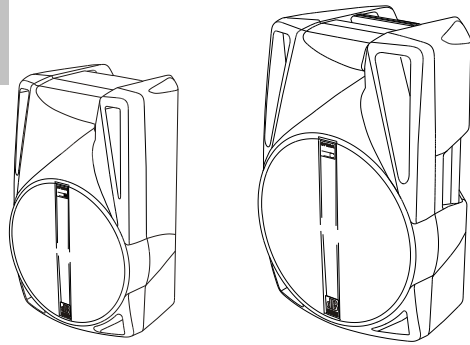

Fig. 1

UTILIZZO A PAVIMENTO (MONITOR)  
FLOOR USES (MONITOR)  
VERWENDUNG AUF DEM BODEN (MONITOR)  
UTILISATION AU SOL (ÉCRAN)

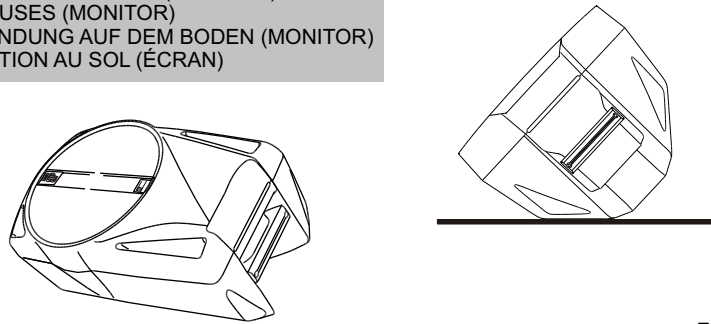

Fig. 2

SUPPORTO PIANTANA STANDARD (D36M)  
STANDARD STAND (D36MM)  
STANDARD-HOCHSTÄNDERFLANSCH (D36MM)  
SUPPORT STANDARD (D36MM)

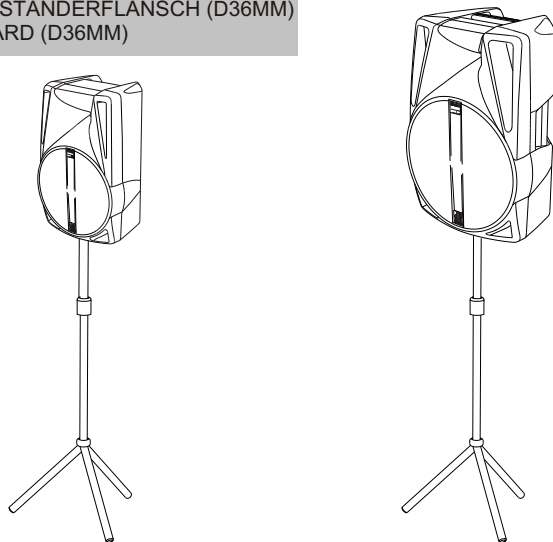

FIG. 3

APPENDIBILE CON STAFFA (OPZIONALE)  
APPENDIX BRACKET (OPTIONAL)  
ANHANG BRACKET (OPTIONAL)  
ANNEXE BRACKET (FACULTATIF)

Kit completo  
Complete kit



Opzione codice / Optional code

WB10 ---> OPERA 210D  
OPERA 410D

WB12-15 ---> OPERA 402D  
OPERA 405D  
OPERA 602D  
OPERA 605D

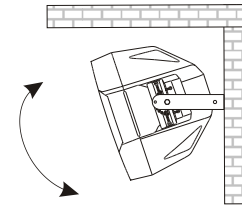
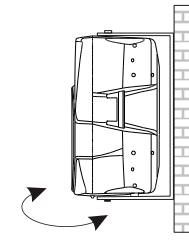
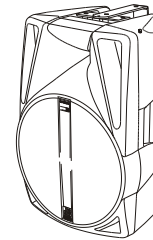
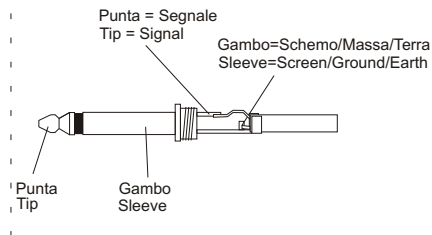

FIG. 4

COLLEGAMENTI  
CONNECTIONS  
ANSCHLÜSSE  
BRANCHEMENTS

Funzionamento sbilanciato con  
connettore jack 1/4" (6,3mm)  
Unbalanced use of stereo 1/4" jack plug



Funzionamento bilanciato con  
connettore jack 1/4" (6,3mm)  
Balanced use of stereo 1/4" jack plug

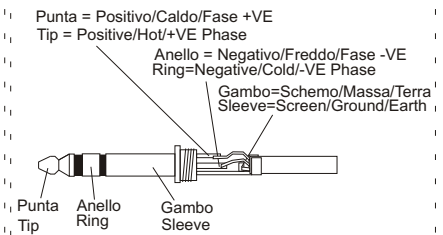

Funzionamento sbilanciato con  
connettore XLR  
Unbalanced use with XLR connectors

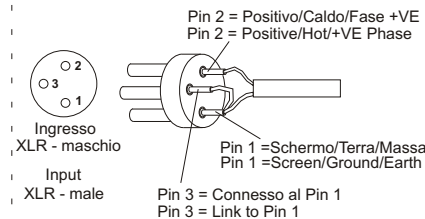

Funzionamento bilanciato con  
connettore XLR  
Balanced use with XLR connectors

